



For use by Principal Authority			
Application number:		Permit Number:	
Date Received:		Roll Number:	

Project Information

Address:			
Unit number:	Lot/Con:	Postal Code:	
Municipality:		Plan number:	
Project value:		Area of work: (Sq.m / Sq.ft.)	
Are there any overhead wires on site: <input type="checkbox"/> Yes <input type="checkbox"/> No			
If yes, please indicate proximity from pool to wires : _____ m			

Swimming Pool Details

<input type="checkbox"/> In-Ground Pool	Dimensions		
	_____ x _____ x _____	Round pool:	_____ ϕ
<input type="checkbox"/> On-Ground Pool	Dimensions		
	_____ x _____ x _____	Round pool:	_____ ϕ
<input type="checkbox"/> Above Ground Pool	Dimensions		
	_____ x _____ x _____	Round pool:	_____ ϕ

Please indicate fence style protecting pool, see "Fence Style Guide" attached.

Applicant

Applicant is Owner or Authorized Agent of Owner (if selected, complete and attach authorization form)

Last name:

First Name:

Corporation or Partnership:

Address:

Unit No:

Lot/Con:

Postal code:

Province:

Municipality:

Telephone Number:

Cell number:

Email:

Owner

Last name:

First Name:

Corporation or Partnership:

Address:

Unit No:

Lot/Con:

Postal code:

Province:

Municipality:

Telephone Number:

Cell number:

Email:

Please indicate fence style protecting pool, see "Fence Style Guide" attached.

Feb-20

Swimming Pool Installer

Last name:		First Name:	
Corporation or Partnership:			
Address:			
Unit No:	Lot/Con:	Postal code:	
Province:		Municipality:	
Telephone Number:		Cell number:	
Email:			

Declaration of Applicant

I the applicant, acknowledge that the information contained in this application, attached plans and specifications, and other attached documentation is true to the best of my knowledge and that if the owner is a corporation or partnership, I have the authority to bind the corporation or partnership.

Date:	Signature:
-------	------------

Personal information contained in this form is collected under the authority of subsection 8(1.1) of the Building Code Act, 1992, and will be used in the administration and enforcement of the Building Code Act, 1992. Questions about the collection of personal information may be addressed to the Chief Building Official of the City of Port Colborne.

Please indicate fence style protecting pool, see "Fence Style Guide" attached.

Feb-20

Completing this Form

Fence

Please indicate fence style protecting pool, see "Fence Style Guide" attached.

Required Supplemental Information

In addition to the submission of this completed form the submission must also include a drawing of the site on which the swimming pool is to be installed. The drawings shall include all dimensions for the size of the lot, dimensions to the shape and location of the pool and its related equipment from property lines and buildings, the location and width of any easements on the property, and any other feature or encumbrance which could affect or be affected by the proposed swimming pool installation. The drawings shall be submitted in duplicate.

Building Permit

If the use of the swimming pool is solely for the use of the public, the installation of the swimming pool requires a building permit. A swimming pool permit is not required provided a building permit is obtained.

Hydro

The required drawing shall include the location of all overhead hydro wires on or adjacent to the property on which the swimming pool is to be installed. Minimum setbacks from the hydro lines are applicable and Canadian Niagara Power or Ontario Hydro may be required to provide approval where these required setbacks are imposed upon.

Other Approvals

Where the installation of a swimming pool requires approvals from the Regional Municipality of Niagara, Ministry of Transportation, Niagara Escarpment Commission, or Niagara Peninsula Conservation Authority these approvals shall be submitted with this application in order to constitute a complete application.

Location of Swimming pools

Swimming pools shall be located in the interior side yard and rear yard;

- No interior wall surface shall be located closer than 1.0 metres (3' – 3") to any rear or side lot line;
 - No interior wall surface shall be located closer to any street line than the minimum setback required there from;
- and
- No water circulating equipment such as pumps or filters shall be located closer than 3.0 metres (9' – 8") to any side lot line or 1.0 metres (3' – 3") to any rear lot line.
 - A building or structure containing or enclosing an above-ground or in-ground pool shall not be located in any required yard and shall comply with all applicable accessory structure provisions of the zone in which such building or structure is located.

Fence Style Guide

Boards on one side

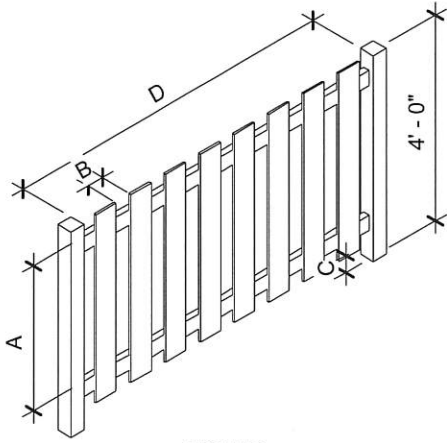

NOTES

4" spacing between boards (B), if rail spacing is < 3'-0" (A)
 2" spacing between boards (B), if rail spacing is > 3'-0" (A)

4" spacing from grade to board (C) if grade is concrete

(D) is max of 8'-0"

Boards on two sides

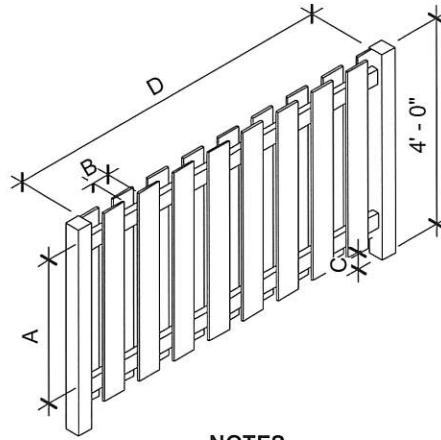

NOTES

4" spacing between boards (B), if rail spacing is < 3'-0" (A)
 2" spacing between boards (B), if rail spacing is > 3'-0" (A)

4" spacing from grade to board (C) if grade is concrete

(D) is max of 8'-0"

Wrought Iron Fence

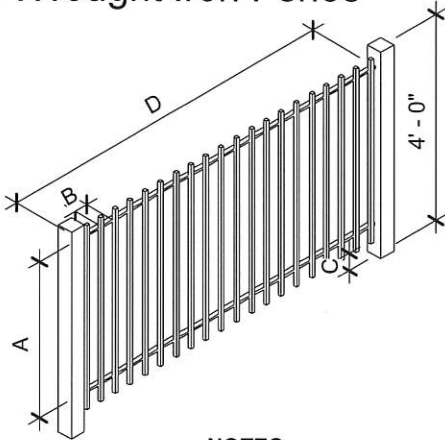

NOTES

4" spacing between pickets (B), if rail spacing is < 3'-0" (A)
 2" spacing between pickets (B), if rail spacing is > 3'-0" (A)

4" spacing from grade to picket (C) if grade is concrete

(D) is max of 8'-0"

Chain Link Fence

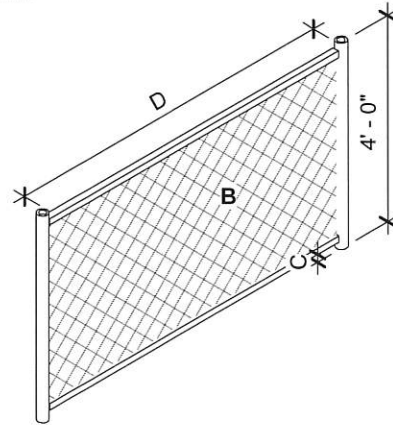

NOTES

50mm (2") spacing (B), if rail spacing is < 3'-0" (A)
 38mm (1.5") spacing (B), if rail spacing is > 3'-0" (A)

4" spacing from grade to picket (C) if grade is concrete

(D) is max of 8'-0"



PORT COLBORNE

By-law 5510/107/10

City of Port Colborne

Fence Types

www.portcolborne.ca

AGENT AUTHORIZATION FORM

A. Project Information			
Civic Address:			
Legal Description:			
B. Party to be Authorized			
Last Name:		First Name:	
Corporation/Partnership:			
Address:			
Municipality:			
Cell Number:			
Email:			

C. Declaration of Owner:

I, _____, being the registered owner of the above noted property, hereby authorize the party stated in Section B of this form to make application for a building permit on my behalf to the Building Department of the City of Port Colborne in accordance with the applicable requirements of the Ontario Building Code for the purpose of the identified project.

Date: _____ Signature: _____