

Request for Relief from Noise By-law

PERMIT

This form represents a request for Relief from Noise By-law within the City of Port Colborne. The property in question requesting the relief from such By-law will be posted on the City's website. Citizens can review the request and submit comments in regards to the relief from By-law request. By-law Services will review comments and make a final decision on the request within 45 days of submission. In order for By-law Services to proceed with a request for a relief from a By-law, it is required that you complete this form in **FULL** including your signature and date.

Requestor Information:

Would you like to pay for this application online? *

No (Payments must be made in person at City Hall upon submission before application will be reviewed by City staff)

Yes (Credit Card payments only) *Payment of \$190.00 confirmed*

First name *

Adrian

Last name *

Gentile

Address *

9 Chestnut St

City *

Port Colborne

Postal Code *

L3K1R3

Is the property address in question the same as above? *

Yes

No

Where is the private function taking place? *

Private function taking place on private property - \$190.00

Email *

[Redacted]

Phone Number *

[Redacted]

Please upload a file of your Site Plan *

File Name

 03 - Civil Drawings - July 20.pdf
1.9 MB

Please upload a file of your Neighbour(s) notification: *

File Name

 Rankin Extended Working Hours Request - Public Letter.docx
62.4 KB

Date(s) of Exemption Request: *

2024-05-13 - 2024-09-13

Hours of Exemption Request: *

~~630am - 8pm~~ 7am - 830pm DAILY, Sunday 9am - 1pm, No Seat Hours
M-Fri

Type of Noise Exemption (music, fireworks, etc..) *

Construction

Specify equipment being used: *

Machine set up and dismantle, temp lighting, generators, hand power tools, trucks idling, temporary lifts.

Registered Charitable Organization? *

Yes
 No

Not for Porfit Organization? *

Yes
 No

Comments:

Rankin Construction is building a 5 storey affordable housing building for non for profit organization Port Cares. We will not need extended hours on all days but there may be a day or two per week where due to scheduling constraints and / or material curing times that we need to stay later than usual to complete said task. Some mornings there will be crews on site prior to the 7am noise by-law. We will not start work till 7am but set up of cranes, concrete pumps, lifts, material handling may begin prior to 7am. We are doing our very best to ensure the safety and comfort of all neighbors and are doing our very best to ensure they are all kept happy.

Note: Application must be completed and submitted with payment, if applicable, 60 days prior to the event. Registered Charitable Organizations and Not for Profit Organizations are exempt from the Variance Fee.

Disclaimer: The personal information requested on this form is being collected for the purpose of conducting a By-law Enforcement investigation and may be shared with the applicable departments and agencies for the purpose of initiating action. Collection of personal information is governed, authorized, and protected by the Freedom of Information and Protection of Privacy Act. By providing this information, you consent to its use for the above purposes.

Signature *

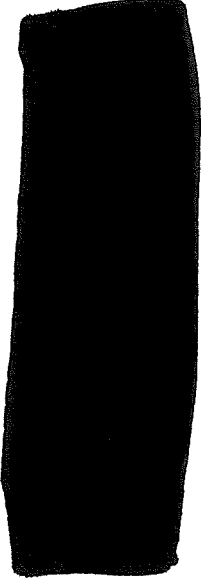
A large black rectangular redaction box covering the signature area.

Date

5/6/2024



Request for Relief From Noise By-law Payment Page

Application Fee (due upon submission):

Private function taking place on private property - **\$190.00**

Private function taking place on City property - **\$127.00**

Please be advised that a 2.40% convenience fee applies to all online credit card payments

The property in question requesting the relief from such By-law will be posted on the City's website. Citizens can review the request and submit comments in regards to the relief from By-law request. By-law Services will review comments and make a final decision on the request within 45 days of submission.

Thank You.

Your request for Relief from Noise By-law Form has been submitted.

City staff will now review your application and be in contact with you with-in 45 days to provide you with a response.

Please note: If making payment in person, the application will not be reviewed until payment is recieved.

If you have any questions, call 905-835-2900 x200 or email bylawenforcement@portcolborne.ca.

GEODETIC BENCHMARK INFORMATION

ELEVATIONS HEREON ARE GEODETIC AND WERE DERIVED FROM THE TOPNET RTK NETWORK, NAD83 CSRS, VERSION 3, EPOC 2010.

GENERAL NOTES:

- READ ALL CIVIL DRAWINGS IN CONJUNCTION WITH ALL CONTRACT DOCUMENTS, INCLUDING ARCHITECTURAL, STRUCTURAL, ELECTRICAL, MECHANICAL, LANDSCAPE AND VENDOR DRAWINGS AS APPLICABLE.
- THE CONTRACTOR FOR ANY PORTION OF WORK SHALL VISIT THE SITE AND SHALL BE THOROUGHLY FAMILIAR WITH ALL THE PHYSICAL FEATURES THAT MAY AFFECT THE WORK IN ANY WAY.
- THE CONTRACTOR MUST FIELD CHECK AND VERIFY ALL DIMENSIONS, ELEVATIONS AND EXISTING CONDITIONS AND REPORT ANY DISCREPANCIES TO THE CONSULTANT PRIOR TO COMMENCEMENT OF ANY WORK.
- THE CONTRACTOR SHALL KEEP WORK SITES CLEAN AND FREE OF ALL CONSTRUCTION DEBRIS DURING THE PROCESS OF CONSTRUCTION AND LEAVE THE SITE CLEAN UPON COMPLETION OF WORK OR PORTIONS OF THE WORK.
- THE CONTRACTOR SHALL OBTAIN APPROVED SERVICE CONNECTION PERMITS FROM THE CITY OF PORT COLBORNE PUBLIC WORKS BEFORE CONNECTING TO EXISTING SEWER, OR WATER MAIN.
- THE CONTRACTOR SHALL NOT OPERATE EXISTING MUNICIPAL WATER SYSTEM VALVES. WATER MAIN FLUSHING, DISINFECTING AND TESTING PLAN TO BE SUBMITTED TO, AND APPROVED BY THE CITY OF PORT COLBORNE PRIOR TO THE PERFORMANCE OF WORK. VALVES CAN ONLY BE OPERATED BY THE CITY OF PORT COLBORNE OPERATIONAL STAFF. THE CITY REQUIRES A MINIMUM OF 48 HOURS WRITTEN NOTICE PRIOR TO ALL WORKS.
- CONSULTANT MUST APPROVE ALL DEVIATIONS FROM THE WORKING DRAWINGS. THE CONTRACTOR MUST KEEP AN ACCURATE RECORD OF ALL CHANGES FROM THE ORIGINAL INFORMATION SHOWN ON THE CONSTRUCTION DRAWINGS.
- FEATURES OF CONSTRUCTION NOT FULLY SHOWN ARE OF THE SAME CHARACTER AS THOSE NOTED FOR SIMILAR CONDITIONS.
- ALL CONSTRUCTION SHALL CONFORM TO THE LATEST EDITION OF THE FOLLOWING:
 - OCCUPATIONAL HEALTH AND SAFETY ACT
 - ONTARIO REGULATION 213/91 - CONSTRUCTION PROJECTS
 - THE ONTARIO BUILDING CODE AND THE NATIONAL BUILDING CODE
 - THE ONTARIO PROVINCIAL STANDARD SPECIFICATIONS / DRAWINGS
 - THE NIKKANA PENINSULA STANDARD CONTRACT DOCUMENTS
- ALL ELEVATIONS AND DIMENSIONS SHOWN ARE IN METERS, UNLESS NOTED OTHERWISE.
- ALL BUILDING ELEVATIONS (MAIN FINISHED FLOOR, TOP OF FOUNDATION, BASEMENT FINISHED FLOOR) TO BE COORDINATED WITH ARCHITECTURAL DRAWINGS.
- ALL NEW GRADING AFFECTING EXISTING SITE FEATURES (TREES, FENCES, LANDSCAPING, FOUNDATION WALLS, RETAINING WALLS, SLABS, BELL PEDESTALS, UTILITY POLES ETC.) TO BE COORDINATED WITH ARCHITECTURAL, STRUCTURAL, ELECTRICAL, MECHANICAL, LANDSCAPE AND VENDOR DRAWINGS AS APPLICABLE.
- PROVIDE APPROPRIATE SHORING FOR TRENCH EXCAVATION IN ACCORDANCE WITH THE LATEST REVISION OF THE OHS&A GUIDELINE FOR CONSTRUCTION PROJECTS.
- MINIMUM HORIZONTAL SEPARATION BETWEEN WATER MAINS AND SEWERS SHALL BE 2.5m. MINIMUM VERTICAL CLEARANCE BETWEEN SEWERS AND WATER MAINS WHICH CROSS IS 500mm.
- RIGID PIPE TRENCH EXCAVATION AS PER OPSD 802.030 FOR EARTH EXCAVATION AND OPSD 802.033 FOR ROCK EXCAVATION, AS APPLICABLE.
- FLEXIBLE PIPE TRENCH EXCAVATION AS PER OPSD 802.010 FOR EARTH EXCAVATION AND OPSD 802.013 FOR ROCK EXCAVATION, AS APPLICABLE.
- ALL SANITARY SEWER CONNECTIONS SHALL BE WITH PRE-MANUFACTURED TEES AND SHALL BE INSTALLED AT A MINIMUM GRADE OF 2% UNLESS NOTED OTHERWISE.
- SANITARY LATERAL INVERTS TO BE CONFIRMED ONCE ARCHITECTURAL BACKGROUNDS ARE PROVIDED AND A BASEMENT FLOOR ELEVATION IS CONFIRMED.
- ALL WATER SERVICING TO COMPLY WITH CSA B137.5, ANSISF 14851, AND CURRENT AWWA STANDARDS.
- ALL WATER SERVICES TO BE INSTALLED WITH TRACER WIRE.
- ALL WATER SERVICES TO BE INSTALLED WITH A MINIMUM OF 1.7m COVER. SEWERS TO BE INSTALLED WITH A MINIMUM COVER OF 2.20m AT THE PROPERTY LINE BELOW THE FINAL ROAD GRADE OR AT SUCH HIGHER ELEVATION ONLY AS MAY BE NECESSITATED BY THE LEVEL OF THE MAIN SEWER. ON PRIVATE PROPERTY THE MINIMUM COVER IS TO BE NO LESS THAN 1.2m.
- ALL WATER MAIN FITTINGS SHALL BE MECHANICALLY RESTRAINED. ALL FITTINGS SHALL BE INSTALLED WITH CORROSION RESISTANT COR-BLUE TEE BOLTS AND NUTS, OR APPROVED EQUAL.
- ALL WATER MAIN FITTINGS SHALL BE CATHODICALLY PROTECTED AS PER OPSD 1109.011.
- BUILDING SERVICES SHALL TERMINATE AT 1.5m FROM THE FACE OF THE BUILDING. SITE SERVICES CONTRACTOR TO COORDINATE WITH THE MECHANICAL CONTRACTOR, THE CONNECTION OF SITE SERVICES, INCLUDING SANITARY STORM AND WATER, TO THE INTERNAL SERVICES.
- GRADING IS NOT TO ADVERSELY AFFECT ADJACENT PROPERTIES.
- ALL WORK WITHIN MUNICIPAL RIGHT-OF-WAYS REQUIRES MUNICIPAL CONSENT PERMIT.
- THE CONTRACTOR SHALL ENSURE ALL NEW AND EXISTING MANHOLES / CATCHBASINS / VALVES AND ANY OTHER APPURTENANCE WITHIN THE CONSTRUCTION AREA, TO MATCH FINISHED GRADE, AS REQUIRED.
- NEW MAINTENANCE HOLES TO CONFORM TO OPSD 701.010 - 701.015 AS APPROPRIATE, WITH TYPICAL MAINTENANCE HOLE BENCHING AS PER OPSD 701.021.
- NEW CATCH BASINS TO BE PER OPSD 705.010 WITH GRATES TO OPSD 400.010.
- PRE-CONSTRUCTION SURVEY TO BE COMPLETED BY CONTRACTOR PRIOR TO COMMENCEMENT OF WORK.
- REMOVAL OF EXISTING FEATURES OF THE SITE ARE TO BE CARRIED OUT IN ACCORDANCE WITH OPS 510 AS APPLICABLE.
- TRENCHES IN ROADWAYS, SHOULDERS, SIDEWALKS, AND DRIVEWAYS TO BE BACKFILLED WITH GRANULAR 'A' AND COMPACTED TO 100% SPDD. OTHER AREAS MAY BE BACKFILLED WITH SELECT NATIVE MATERIAL AND COMPACTED TO 95% S.P.D. ROAD ASPHALT TO BE MILLED TO 40mm DEEP AND 300mm WIDE ON EACH SIDE AND REINSTATED WITH 50mm HL3 HS BASE OR MATCH EXISTING, WHICHEVER IS GREATER, AND 40mm HL3 HS TOP. SHOULDERS TO BE GRANULAR 'A' COMPACTED AND PLACED TO A DEPTH OF 150mm. GRASSED AREAS TO BE RESTORED TO THEIR ORIGINAL CONDITION.
- ALL BARRIER CURBS AS PER OPSD 600.110.
- SIDEWALKS AS PER OPSD 310.010. IN LOCATIONS WHERE SIDEWALK IS ADJACENT TO CURB AND GUTTER, SIDEWALK TO BE AS PER OPSD 310.020. SIDEWALKS TO BE 150mm THICK AT DRIVEWAYS AND 125mm THICK AT ALL OTHER AREAS. 30MPa CONCRETE COMPLETE WITH 100mm THICK GRANULAR 'A' BASE COMPACTED TO 100% SPDD. SIDEWALKS ARE TO MEET THE LATEST CITY OF PORT COLBORNE STANDARDS AS WELL AS THE LATEST NPCSD FOR TACTILE SURFACES AND ACCESSIBLE SIDEWALK.
- ASPHALT AND GRANULAR CROSS SECTION TO BE CONFIRMED BY GEOTECHNICAL ENGINEER. IF CHANGES TO THE ASPHALT CROSS SECTIONS ARE REQUIRED BASED ON GEOTECHNICAL CONSIDERATIONS, THE CONSULTANT SHALL BE NOTIFIED PRIOR TO COMMENCEMENT OF ANY WORK.
- SEALED COMPACTION TEST REPORTS TO BE PROVIDED BY THE CONTRACTOR THROUGH A THIRD PARTY TESTING AGENCY.
- PROVIDE SILT FENCE PROTECTION ON ALL NEW AND EXISTING CATCH BASIN COVERS AND AROUND PERIMETER OF AREA OF WORK DURING CONSTRUCTION AND REMOVE UPON COMPLETION.

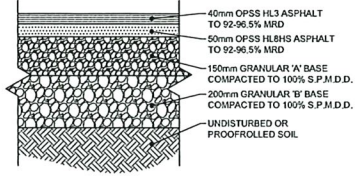

STANDARD DUTY ASPHALT DETAIL

SCALE: 1:10

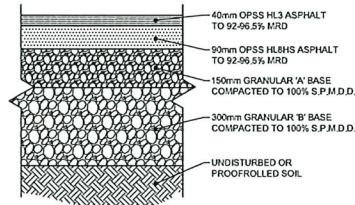

HEAVY DUTY ASPHALT DETAIL

SCALE: 1:10



KEY PLAN

SCALE: NTS

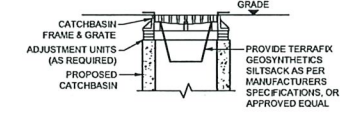

TYP. SEDIMENT TRAP

SCALE: 1:25

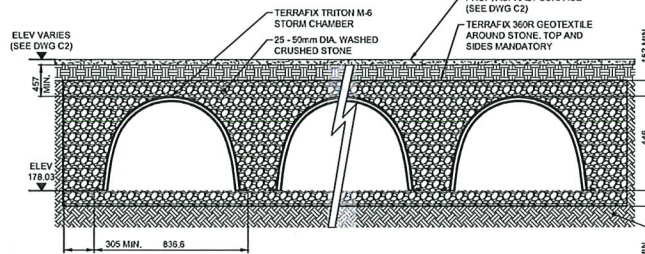

STORM CHAMBER TYPICAL DETAIL

SCALE: NTS

- GENERAL NOTES**
- REFER TO TERRAFIX GEOSYNTHETICS INC'S CURRENT RECOMMENDED INSTALLATION GUIDELINES FOR TRITON M-6 STORM CHAMBER COMPLETE WITH INSPECTION PORTS AT THE HEADER ROW.
 - INSPECTION PORTS TO BE INSTALLED WITH HOPE RISER, 145mm DIA 150mm THICK CONCRETE TOP SLAB AND OPSD 401.020 MANHOLE FRAME AND COVER AS PER THE TRITON STANDARD DETAILS DRAWING.
 - ALL TRITON M-6 CHAMBERS MUST BE INSTALLED IN ACCORDANCE WITH ALL APPLICABLE LOCAL, PROVINCIAL AND FEDERAL REGULATIONS.
- THIRD PARTY SOILS CONSULTANT RESPONSIBLE FOR ENSURING THE REQUIRED BEARING CAPACITY OF SUB-GRADE SOILS (TYP.)

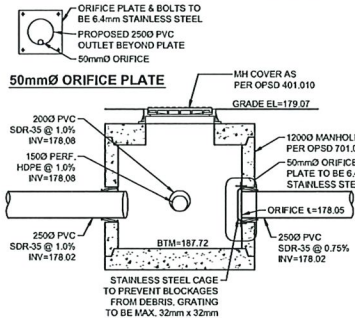

STAINLESS STEEL ORIFICE PLATE DETAIL

SCALE: NTS

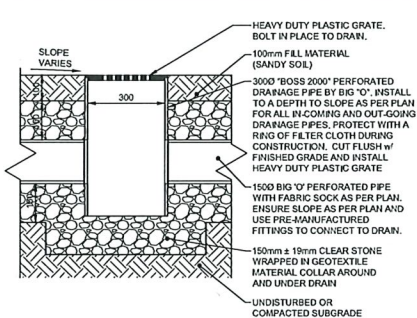

TURF DRAIN DETAIL

SCALE: 1:10



DATE
JUN 17, 2023
JUN 25, 2023
MAY 09, 2023
JUL 10, 2023
OCT 05, 2023

REV.	DRAWING REVISION
0	ISSUED FOR SITE PLAN APPROVAL
1	ISSUED FOR SITE PLAN APPROVAL
2	ISSUED FOR SITE PLAN APPROVAL
3	ISSUED FOR SITE PLAN APPROVAL
4	ISSUED FOR SITE PLAN APPROVAL

CLIENT:
WHITELINE ARCHITECTS INC 83 ONTARIO STREET ST CATHARINES, ON

PROJECT:
PROPOSED 5 STOREY APARTMENT BUILDING 9 CHESTNUT STREET PORT COLBORNE, ON FILE NO. D11-01-23

SHEET TITLE:
GENERAL NOTES, TYPICAL DETAILS & KEY PLAN

DATE:
DEC. 2022

SCALE:
AS SHOWN

DR. BY:
JF / AI

CH. BY:
J5 / JH

JOB No.:
221120

DWG.	REV.
CO	4

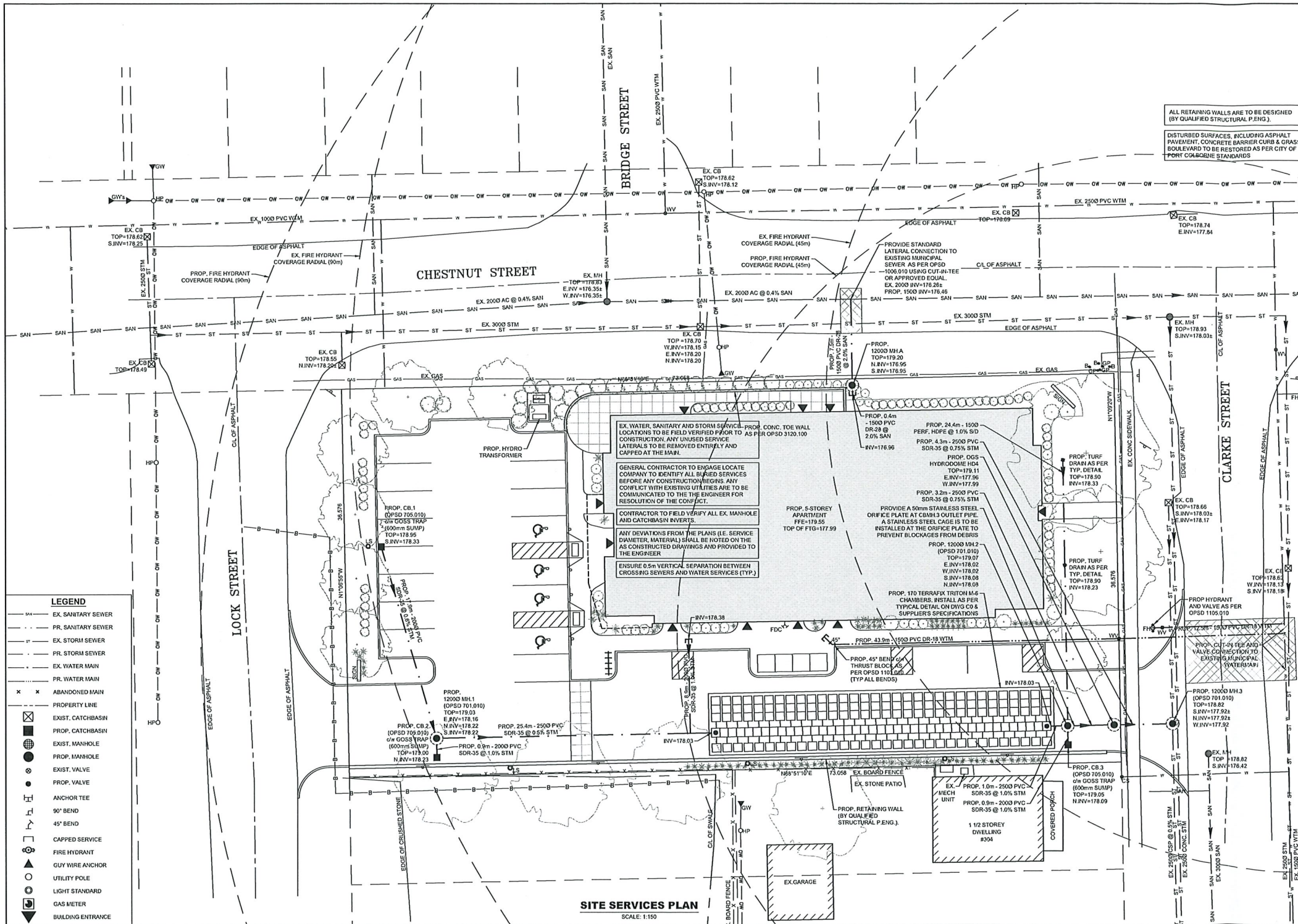

ALL RETAINING WALLS ARE TO BE DESIGNED (BY QUALIFIED STRUCTURAL P.ENG.).
 DISTURBED SURFACES, INCLUDING ASPHALT PAVEMENT, CONCRETE BARRIER CURB & GRASS BOULEVARD TO BE RESTORED AS PER CITY OF PORT COLBORNE STANDARDS

EX. WATER, SANITARY AND STORM SERVICES - PROP. CONC. TOE WALL LOCATIONS TO BE FIELD VERIFIED PRIOR TO AS PER OPSD 3120.100 CONSTRUCTION. ANY UNUSED SERVICE LATERALS TO BE REMOVED ENTIRELY AND CAPPED AT THE MAIN.

GENERAL CONTRACTOR TO ENGAGE LOCATE COMPANY TO IDENTIFY ALL BURIED SERVICES BEFORE ANY CONSTRUCTION BEGINS. ANY CONFLICT WITH EXISTING UTILITIES ARE TO BE COMMUNICATED TO THE ENGINEER FOR RESOLUTION OF THE CONFLICT.

CONTRACTOR TO FIELD VERIFY ALL EX. MANHOLE AND CATCHBASIN INVERTS.

ANY DEVIATIONS FROM THE PLANS (I.E. SERVICE DIAMETER, MATERIAL) SHALL BE NOTED ON THE AS CONSTRUCTED DRAWINGS AND PROVIDED TO THE ENGINEER.

ENSURE 0.5m VERTICAL SEPARATION BETWEEN CROSSIG SEWERS AND WATER SERVICES (TYP.)

SITE SERVICES PLAN
 SCALE: 1:150



REV.	DRAWING REVISION	DATE
0	DESIGNED FOR SITE PLAN APPROVAL	JAN. 10, 2023
1	DESIGNED FOR SITE PLAN APPROVAL	JAN. 25, 2023
2	DESIGNED FOR SITE PLAN APPROVAL	MAY 03, 2023
3	DESIGNED FOR SITE PLAN APPROVAL	JUL. 20, 2023
4	DESIGNED FOR SITE PLAN APPROVAL	OCT. 05, 2023

CLIENT:
 WHITELINE ARCHITECTS INC
 83 CANTARIO STREET
 ST CATHARINES, ON

PROJECT:
 PROPOSED 5 STOREY APARTMENT BUILDING
 9 CHESTNUT STREET
 PORT COLBORNE, ON
 FILE NO. D11-01-23

SHEET TITLE:
 SITE SERVICES PLAN

DATE:	DEC. 2022
SCALE:	AS SHOWN
DR. BY:	JF/A
CH. BY:	JF/JH
JOB No.:	22120
DWG. REV.	C1 4

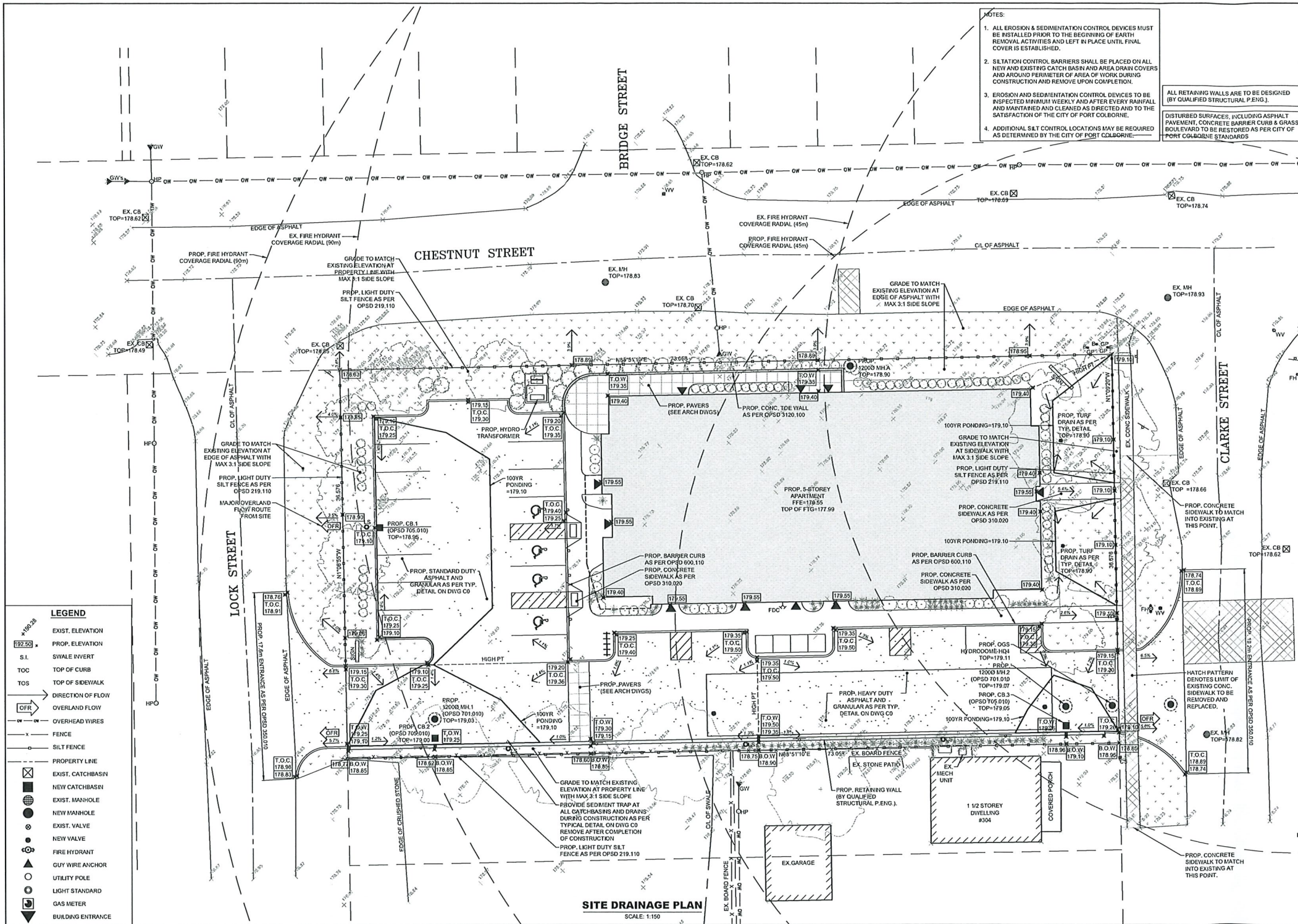

- NOTES:
1. ALL EROSION & SEDIMENTATION CONTROL DEVICES MUST BE INSTALLED PRIOR TO THE BEGINNING OF EARTH REMOVAL ACTIVITIES AND LEFT IN PLACE UNTIL FINAL COVER IS ESTABLISHED.
 2. SILTATION CONTROL BARRIERS SHALL BE PLACED ON ALL NEW AND EXISTING CATCH BASIN AND AREA DRAIN COVERS AND AROUND PERIMETER OF AREA OF WORK DURING CONSTRUCTION AND REMOVE UPON COMPLETION.
 3. EROSION AND SEDIMENTATION CONTROL DEVICES TO BE INSPECTED MINIMUM WEEKLY AND AFTER EVERY RAINFALL AND MAINTAINED AND CLEANED AS DIRECTED AND TO THE SATISFACTION OF THE CITY OF PORT COLBORNE.
 4. ADDITIONAL S&T CONTROL LOCATIONS MAY BE REQUIRED AS DETERMINED BY THE CITY OF PORT COLBORNE.
- ALL RETAINING WALLS ARE TO BE DESIGNED (BY QUALIFIED STRUCTURAL P.ENG.).
- DISTURBED SURFACES, INCLUDING ASPHALT PAVEMENT, CONCRETE BARRIER CURB & GRASS BOULEVARD TO BE RESTORED AS PER CITY OF PORT COLBORNE STANDARDS



DATE	REVISION
JAN. 10, 2023	0 DESIGNED FOR SITE PLAN APPROVAL
JAN. 25, 2023	1 REDESIGNED FOR SITE PLAN APPROVAL
MAY 02, 2023	2 REDESIGNED FOR SITE PLAN APPROVAL
JUL. 20, 2023	3 REDESIGNED FOR SITE PLAN APPROVAL
OCT. 05, 2023	4 REDESIGNED FOR SITE PLAN APPROVAL

CLIENT:
WHITELINE ARCHITECTS INC
83 ONTARIO STREET
ST CATHARINES, ON

PROJECT:
PROPOSED 3 STOREY APARTMENT BUILDING
2 CHESTNUT STREET
PORT COLBORNE, ON
FILE NO. D11-01-23

SHEET TITLE:
SITE DRAINAGE PLAN

DATE:	DEC. 2022
SCALE:	AS SHOWN
DR. BY:	JF/IA
CH. BY:	JF/JH
JOB No.:	22120
DWG. REV.	C2 4

LEGEND

	EXIST. ELEVATION
	PROP. ELEVATION
	SWALE INVERT
	TOP OF CURB
	TOP OF SIDEWALK
	DIRECTION OF FLOW
	OVERLAND FLOW
	OVERHEAD WIRES
	FENCE
	SILT FENCE
	PROPERTY LINE
	EXIST. CATCHBASIN
	NEW CATCHBASIN
	EXIST. MANHOLE
	NEW MANHOLE
	EXIST. VALVE
	NEW VALVE
	FIRE HYDRANT
	GUY WIRE ANCHOR
	UTILITY POLE
	LIGHT STANDARD
	GAS METER
	BUILDING ENTRANCE

SITE DRAINAGE PLAN
SCALE: 1:150



Rankin Construction Inc.

CONTRACTORS & ENGINEERS

20 Corporate Park Dr.
St. Catharines, Ontario
L2S 3W2
Telephone: (905) 684-1111
Fax: (905) 684-1111
stcath@rankinconstruction.ca

605 James Street North
3rd Floor
Hamilton, Ontario
L8L 1K1
Telephone: (905) 525-5153
Fax: (905) 525-9110
ham@rankinconstruction.ca

Subject: Notice of Extended Working Hours at Port Cares Construction Site

Dear Neighbors,

I hope this letter finds you well. We are writing to inform you about some upcoming changes regarding the construction activities at the Port Cares site.

As you may be aware, we have been working diligently on the Port Cares project within the standard hours of 7:00 AM to 5:00 PM from Monday to Friday. However, due to certain project requirements and timelines, there will be a need for us to extend our working hours on some days.

We understand that extended working hours may cause inconvenience, especially if it leads to increased noise levels in the area. Please be assured that we are committed to minimizing any disruption to the best of our abilities.

We will make every effort to ensure that any construction-related noise is kept to a minimum during these extended hours. However, there may be instances where some noise is unavoidable. We sincerely apologize for any inconvenience this may cause and appreciate your understanding and cooperation.

If you have any questions or concerns regarding the construction activities or the extended working hours, please do not hesitate to reach out to us at agentile@rankinconstruction.ca. We are more than happy to address any inquiries or provide further information.

Once again, we apologize for any inconvenience this may cause and thank you for your patience and understanding as we work to complete the Port Cares project.

Sincerely,

Adrian Gentile
Rankin Construction Inc