



PORT COLBORNE

PERMIT APPLICATION TO INSTALL a SWIMMING POOL

For use by Principal Authority			
Permit Number:		Date Received:	
Address:		Roll Number	

Project Information

Municipal Address:			
Unit Number:	Lot/Con:	Postal Code:	
Municipality:		Plan Number:	
Estimated Project Value:		Area of work:	
Are there any overhead wires on site: <input type="checkbox"/> Yes <input type="checkbox"/> No			
If yes, please indicate proximity from pool to wires : _____			

Swimming Pool Details

<input type="checkbox"/> In-Ground Pool	Dimensions
	_____ x _____ x _____ Round pool: _____ ϕ
<input type="checkbox"/> On-Ground Pool	Dimensions
	_____ x _____ x _____ Round pool: _____ ϕ
<input type="checkbox"/> Above Ground Pool	Dimensions
	_____ x _____ x _____ Round pool: _____ ϕ

Please indicate fence style protecting pool, see the fence construction form in this application.

Applicant

Applicant is Owner or Authorized Agent of Owner (if selected, agent of authorization form is required)

First Name:

Last Name:

Corporation or Partnership:

Address:

Unit No:

Lot/Con:

Postal Code:

Province:

Municipality:

Telephone Number:

Cell Number:

Email Address:

Owner

First name:

Last Name:

Corporation or Partnership:

Address:

Unit No:

Lot/Con:

Postal Code:

Province:

Municipality:

Telephone Number:

Cell Number:

Email Address:

Swimming Pool Installer

First Name:

Last Name:

Corporation or Partnership:

Address:

Unit No:

Lot/Con:

Postal code:

Province:

Municipality:

Telephone Number:

Cell number:

Email:

Declaration of Applicant

I _____ acknowledge that the information contained in this application along with supporting documentation is true to the best of my knowledge and that if the owner is a corporation or partnership, I have the authority to bind the corporation or partnership.

Date:

Signature:

Personal information contained in this form is collected under the authority of subsection 8(1.1) of the Building Code Act, 1992, and will be used in the administration and enforcement of the Building Code Act, 1992. Questions about the collection of personal information may be addressed to the Chief Building Official of the City of Port Colborne.

Fence construction

Boards on one side

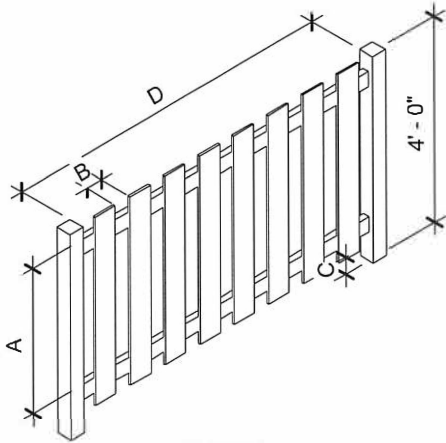

NOTES

4" spacing between boards (B), if rail spacing is < 3'-0" (A)
 2" spacing between boards (B), if rail spacing is > 3'-0" (A)

4" spacing from grade to board (C) if grade is concrete

(D) is max of 8'-0"

Boards on two sides

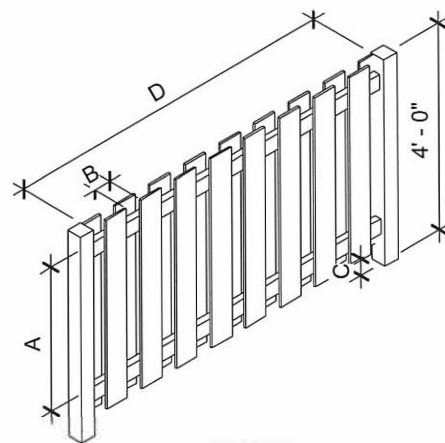

NOTES

4" spacing between boards (B), if rail spacing is < 3'-0" (A)
 2" spacing between boards (B), if rail spacing is > 3'-0" (A)

4" spacing from grade to board (C) if grade is concrete

(D) is max of 8'-0"

Wrought Iron Fence

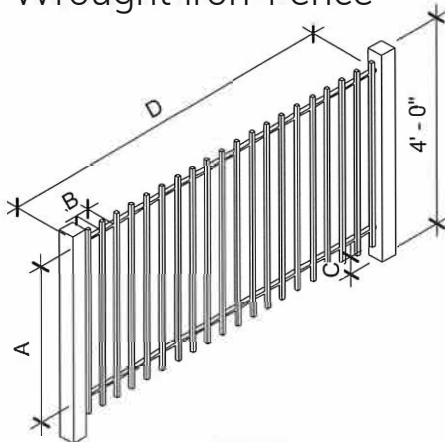

NOTES

4" spacing between pickets (B), if rail spacing is < 3'-0" (A)
 2" spacing between pickets (B), if rail spacing is > 3'-0" (A)

4" spacing from grade to picket (C) if grade is concrete

(D) is max of 8'-0"

Chain Link Fence

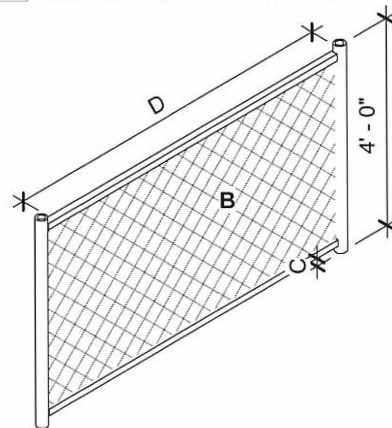

NOTES

50mm (2") spacing (B), if rail spacing is < 3'-0" (A) 38mm (1.5") spacing (B), if rail spacing is > 3'-0" (A)

4" spacing from grade to picket (C) if grade is concrete

(D) is max of 8'-0"



PORT COLBORNE

By-law 5510/107/10

City of Port Colborne

Fence Types

www.portcolborne.ca